



SPECIFICATION FOR APPROVAL

规格承认书

To: 1905241299

产品型号 Par No. : DA13628H12B

类别 Category: Fan Blower Centrifugal

认证 Certification: CE ROHS UL TUV

编号 Spec No: DA13628H12B-A220720 版次 Version: 01

样品数 Quantity: 3 PCS 日期 Date: 2022-07-26

Company Stamp	CUSTOMER APPROVAL Stamp
	
制作: 朱蒸蒸	承认:
复核: 刘良军	核准:
核准:	日期:

电话(TEL): 86-0755-23126453 传真(FAX): 86-0755-23129135

邮箱(MAIL): sales@tenkai-group.com

网址(WEB): [Http://www.tkfan.com](http://www.tkfan.com)

地址(ADD): 深圳市龙华区观澜格澜9路金雄达科技园C栋5楼

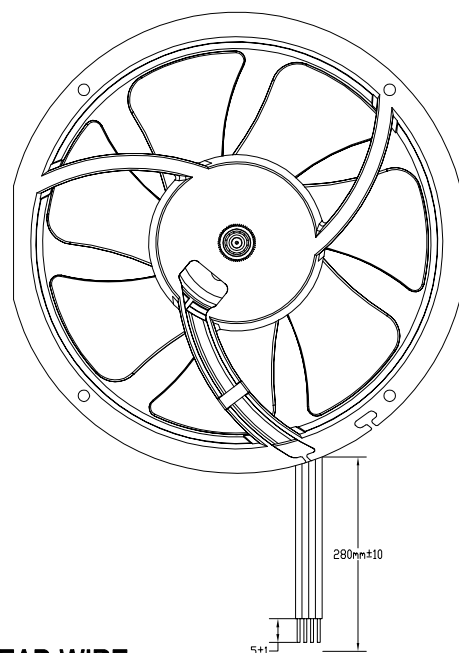
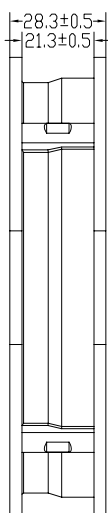
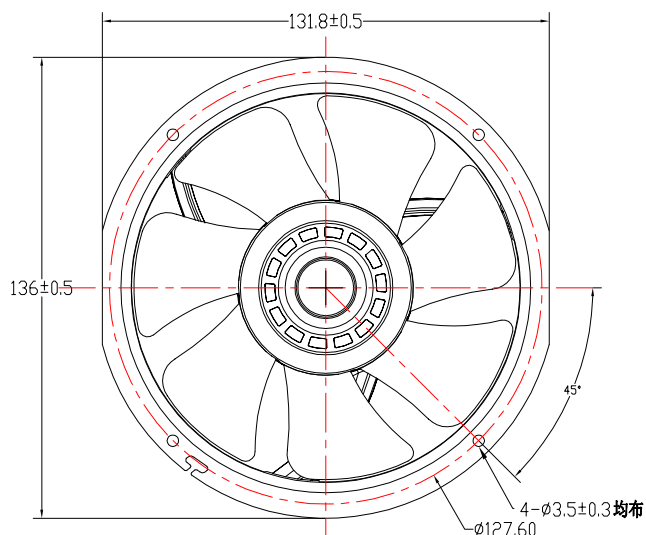

UNIT: $\frac{\text{mm}}{(\text{INCH})}$

LEAD WIRE:

UL 1007#24AWG OR EQUIVALENT

- 1: RED WIRE---(+)**
- 2: BLACK WIRE---(-)**
- 3: YELLOW WIRE---(FG)**
- 4: BLUE WIRE---(PWM)**



DATE
as:20220726

Mark 记号	REASON 变更原因	PROJECTION		单位 UNIT	深圳市腾凯特种机电有限公司 SHEN ZHEN							
				mm	TENKAI GROUP LIMITED							
		比例 SCALE		1:1	型号 Model NO.	DA13628H12B		图号 Drawing NO. DA13628H12B-A220720				
		公差 TOL	LINEAR (0,50] ±0.10 ±0.05 (50,100] ±0.20 ±0.10 (100,+∞) ±0.30 ±0.15	.X .XX ±0.10 ±0.05 ±0.20 ±0.10 ±0.30 ±0.15	ANGULAR X. ±0.5° X.X ±0.1°	制图 Drawing	朱蒸蒸 Date	2022.07.26	描述 Description DC BRUSHLESS BLOWER			
		It is prohibited to duplicate this document without explicit authorization or to hand it over to others for use.				检查 Check	刘良军 Date	2022.07.26	材质 Material	页数 Page	1/1	
						批准 Approved		日期 Date		表面 Finish	版次 Rev	A0

規格參數

SPECIFICATION

Model 型号:			
Item 项目	Unit 单位	Specification 參數	Condition 條件
Dimension 尺寸	Mm 毫米	136X132X28	LxWxThickness 长宽高
Bearing System 轴承类型	----	Two Ball Bearing	----
Rated Voltage 额定电压	VDC	12	----
Operating Voltage Range 操作电压范围	VDC	7.5~13.5	At 25°C
Start-up Voltage 启动电压	VDC	≤7.5	At 25°C
Rated Current 额定电流	Amp 安培	0.12	At Rated 在额定电压下
Lock Rotor Current 锁定电流	Amp 安培	0	Locked 锁死
Rated Power 额定功耗	Watt 瓦特	1.44	At Rated 在额定电压下
Rated Speed 额定转速	RPM 圈/分钟	3100 ± 10%	AT Rated Voltage 30°C
Air Flow 风量	CFM	70.9	In Free Air 无风阻条件
Static Air Pressure 静压	mmH ₂ O	10.6	When Air Flow=0
Noise Level 噪音	dBA	46.2	At Rated Speed 额定速
Polarity protection 反向保护	--	Reverse protection	YES
Other Spec.	Tachometer Output 转速反馈		YES
	Soft-restart function 软启动		YES
	Lock Protection 锁定保护		YES
	Lock Rotor Alarm 锁定报警		NO
	PWM Control 速度控制		YES
	Thermal Control 过热保护		NO
	Over voltage protection 过压保护		NO
	Over current protection 过流保护		NO
	fixed constant speed Function 恒速功能		NO
Connection Lead Type 连接方式	Lead Wire 导线型号	280mm 1007#24AWG	See Page 2 见图纸
	Connector 端子	NO	Not Required
Life Expectancy 预期寿命	Hours 小时	50000hrs	At 25°C 在 25°C 条件下
Net Weight 净重	g 克	210g	1PCS
备注 Note	正反转控制		

絕緣耐壓 Dielectric Strength	5mA Max./導線与外框間測量，500VAC/min 5mA Max./Measured between lead wire(+)and frame at 500VAC/min
極數 Number of Pole	4 極 4 Poles
EMC	
運轉溫/濕度範圍 Operating temp. Range	溫度/temperature: -40℃~+80℃ 濕度/Humidity: 35%~85%RH
絕緣阻抗 Insulation Resistance	10MΩ /裸線与外框間測量，500VDC/min 10MΩ/between unshackled wire and frame at 500VDC/min
耐濕性 Humidity	電器規格依據 MIL-STD 202F Method 103B 濕度: 95%RH, 溫度: 40±2℃ According to MIL-STD 202F Method 103B Humidity: 95%RH,Temp.: 40±2℃
熱衝擊 Thermal Shock	電器規格依據 MIL-STD 202F Method 107D According to MIL-STD 202F Method 107D
絕緣階段 Insulation Shock	UL: A 種 UL: Class A

MTBF REPOPT

STARTED DATE: 2009.5.16

FINISHED DATE: 2009.10.20

TEST CONDITIONTEST (1) VOLTAGE:12VDC (2) TEMPERATURE: 75°C	ITEM	SPECIFICATION	TEST SAMPLES	20
	OPERATION VOLTAGE	12VDC±10%	TEST HRS/EA	2,200
	CUPPENT DPAIN	MAX ≤0.12A	TOTAL TEST HRS	44,000
	SPEED	3100RPM±10%	FAILURE Q'TY	0
	ACOUSTICAL NOISE		CONFIDENCE LEVEL	90%
			MTBF	53905hours

FAILURE DEFINITION (1) CURRENT:= 10%/ -30%of Original value (2) RPM: 30%/ -15%of Original value (3) NOISE Over±10% of LEVEL: origin	ITEM	CHECK POINT AT THE HOURS							
	TEST DURATION(HRS)	250	500	1k	1.5k	2k	2.2k		
	ACCUMULATED FAILURE Q'TY	0	0	0	0	0	0		
	SURVIVAL Q'TY	20	20	20	20	20	20		
	ACCUMULATED FAILURE RATIO	0%	0%	0%	0%	0%	0%		
	FAILNO.TEST TIME(HRS)SURVIVAL Q'TY								
ACCUMULATED FAIL RATIO									
DESCRIPTION									
TEST RESULT: 1. FORMULA OF FIGURING OUT ACCELERATION FACTOR: Tu: Required Temp (25°C) Ta: Experiment Temp.(75°C) $AF = 2^{\wedge} \left[\frac{Ta - Tu}{75 - 25} \right]$ $= 2^{\wedge} \left[\frac{75 - 25}{10} \right]$ $= 32$ MTBF=[ACTUAL TEST TIME*SAMPLE Q'TY]*AF/TR/SAMPLE Q'TY MTBF=[(2200*20)*32]/1.3026/20=53905HOURS					2. CONFIDENCE LEVEL: ACCORDING TO GEM TABLE90% ZERO FAILURE TR=1.3026				

APPROVED BY: BOPING GONG

CHECKED BY: SHU LIN XIE

TESTED BY: JUN ZHANG

风扇特性曲线风量风压测试报告

The Report of Fan Performance P-Q Curve Test

1.产品特性依照 AMCA-210 标准在双箱里包括风量与风压的测试。

The performance including air flow and air pressure measured in Double Chamber is measured according to AMCA210-92 standard.

测试编号(No.): 5253

测试日期(Date) : 2022/06/17

2.测试数据:

序号 No.	项目 Item	规格 Specification	单位 Unit
1	测试电压 Test Voltage	12	VDC
2	转速 Speed	3100	RPM
3	大气压力 Barometric Pressure	761.5	mmHg
4	相对湿度 Relative Humidity	50	%
5	最大风量(零静压时)Max.Air Flow(At Zero Static Pressure)	70.9	CFM
6	最大风压 (零风量时) Max. Air Pressure(At Zero Air Flow)	10.6	mmH ₂ O

3.P-Q 数据及曲线 P-Q Data and Curve

序号	mmAq	CFM	A	Watt	RPM
1	10.63	0			
2	8.33	11.25			
3	3.51	41.39			
4	3.28	43.72			
5	3	47.08			
6	2.6	50.96			
7	1.04	63.1			
8	0	70.85			

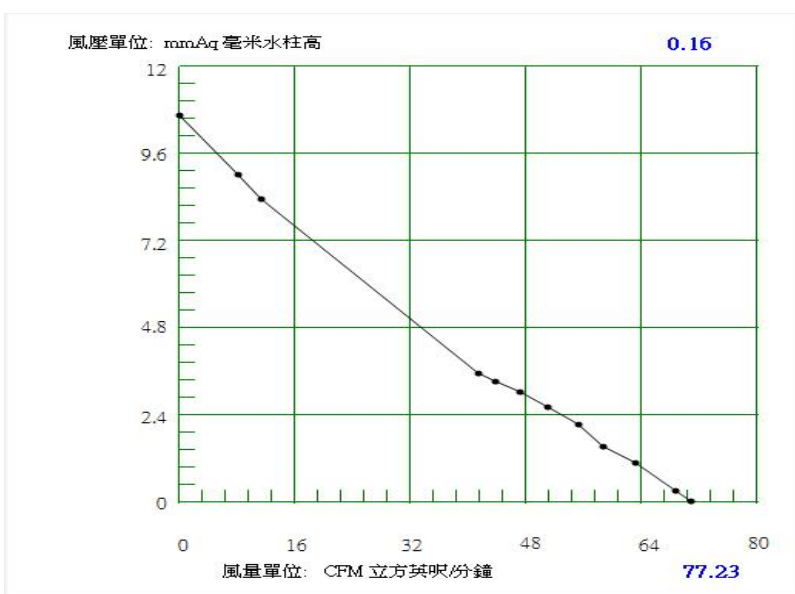

风扇特性曲线 PWM 测试报告

The Report of Fan Performance PWM Curve Test

测试编号(No.):666

测试日期(Date) : 2022-07-26

1.测试数据:

序号	百分比	转速	单位 Unit
1	0 %	3100	RPM
2	10 %	2800	RPM
3	20 %	2200	RPM
4	30 %	1600	RPM
5	40 %	1200	RPM
6	50 %	停止	RPM
7	60 %	1200	RPM
8	70 %	1500	RPM
9	80 %	2100	RPM
10	90 %	2700	RPM
11	100 %	3100	RPM

3.PWM 数据及曲线 PWM Data and Curve

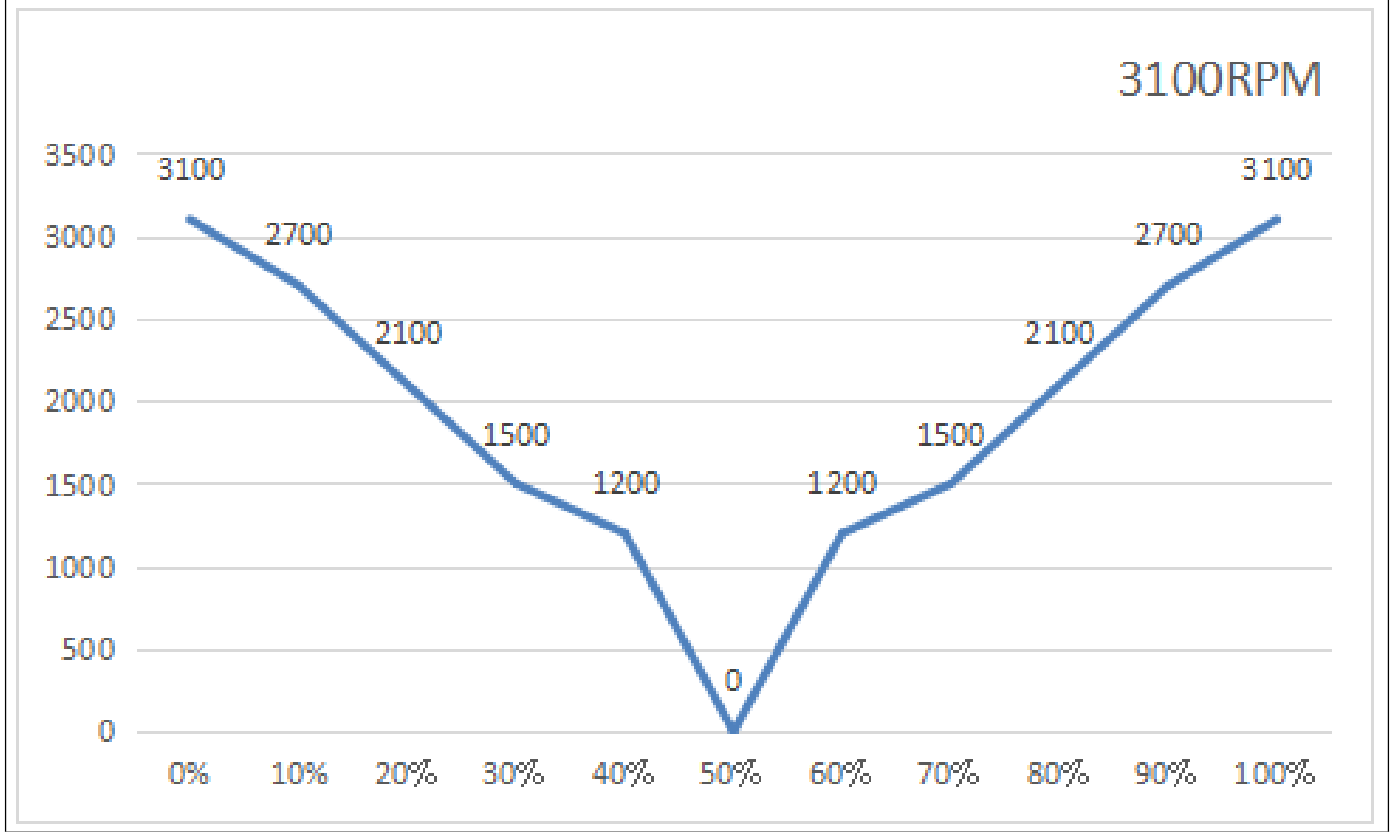

噪音测试报告

The Report of Acoustic Noise Test

报告编号 Report No.TN1511309

样品名称 Sample Name	Brushless Fan / Blower
测试条件 Test Condition	测试方法 Test Method
1.温度 Temperature: 31 °C 2.湿度 Humidity: 75 %RH	1.测试位置 Test Position : 180° 2.测试距离 Test Distance:1.0M From the fan intake 3.背景噪音 Background Noise: 19.1dB(A) 4.测试依照标准 ISO3745 执行 This test executes according to ISO3745 standard
测试设备 Test Equipment: 声望 VA-Lab2 二通道噪声频谱分析仪 BSWA VA-Lab2 double channels noise Spectrum Analyzer	
测试结果 Test Result: Leq:46.20dB(A); 测试距离 Test distance: 1 meter	
倍频段频谱图 Octave-Band(1m)	
<p>坐标 X: SPL(A)O Y: 46.20dB 中心频率</p>	
测试结果 Test Result: Leq:16.1dB(A); 背景噪音 Background Noise	
<p>坐标 X: SPL(A)O Y: 16.10dB 中心频率</p>	

※本报告未经许可严禁擅自更改其中内容 Do not change the content of this report without written permission of authority;
※一般情况, 委托检验结果仅对所检验样品有效 Generally, commission test is responsible for the tested samples only;
※报告无主检、审核人签字无效 The test report is invalid without the signatures of Author and Reviewer.

实物图

The pictures

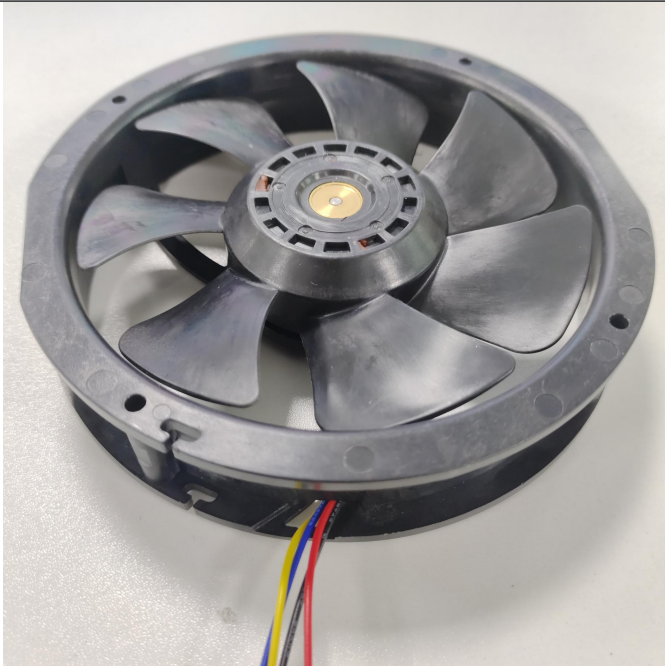

功能描述

Functional description

一. PWM CONTROL SIGNAL PWM 控制信号:

SIGNAL VOLTAGE RANGE 控制电压输入范围:0.0~+5.0VDC

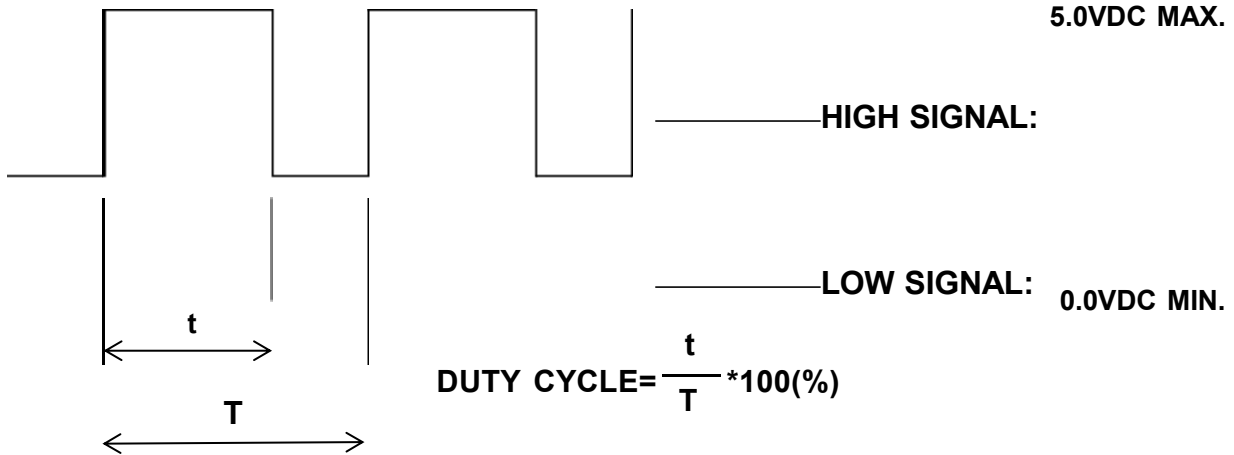

- THE FREQUENCY FOR CONTROL SIGNAL OF THE FAN SHALL BE ABLE TO ACCEPT 16K~32 KHZ.
- THE PREFERRED OPERATING POINT FOR THE FAN IS 25K HZ.
- AT 100% DUTY CYCLE,THE ROTOR WILL SPIN AT MAXIMUM SPEED.
- AT 0% DUTY CYCLE,THE ROTOR WILL STOP.
- WHEN CONTROL SIGNAL LEAD DISCONNECTED,THE FAN WILL MAXIMUM SPEED.
- AT 25K 3%~5% DUTY CYCLE,THE FAN WILL BE ABLE TO START FROM A DEAD STOP.
- THE FAN SPEED CONTROL IS CLOSED-LOOP.

转速信号反馈介绍

FG speed feedback signal is introduced

FG (Tach output type) Connection Diagram

Fan with FG function will create a square wave output. You can know fan speed by sensing the output wave frequency. Most dc fan have four pole. So when fan run for one round, there will be two high level pulse. About other Multipole brushless fan, high level pulse will be different.

But please notice if you want to sense it's output wave, there is a external circuit. Please check the circuit Diagram below. There is no pull-up and VCC value limit. But please notice the Max I_{in} have to be small than 20mA.

Inside of DC fan

