



SPECIFICATION FOR APPROVAL

规格承认书

To: 160330738

产品型号 Par No. : BA3507M12S

类别 Category: Fan Blower Centrifugal

认证 Certification: CE ROHS UL TUV

编号 Spec No.: BA3507M12S-A1801 版次 Version: 02

样品数 Quantity: 1 PCS 日期 Date: 2024-05-27

Company Stamp	CUSTOMER APPROVAL Stamp
制作: YY	承认:
复核: 尤瑞鹏	核准:
核准:	日期:



电话(TEL): 86-0755-23126453 传真(FAX): 86-0755-23129135

邮箱(MAIL): sales@tenkai-group.com

网址(WEB): [Http://www.tkfan.com](http://www.tkfan.com)

地址(ADD): 深圳市观澜街道第三工业区盈丰路 32 号

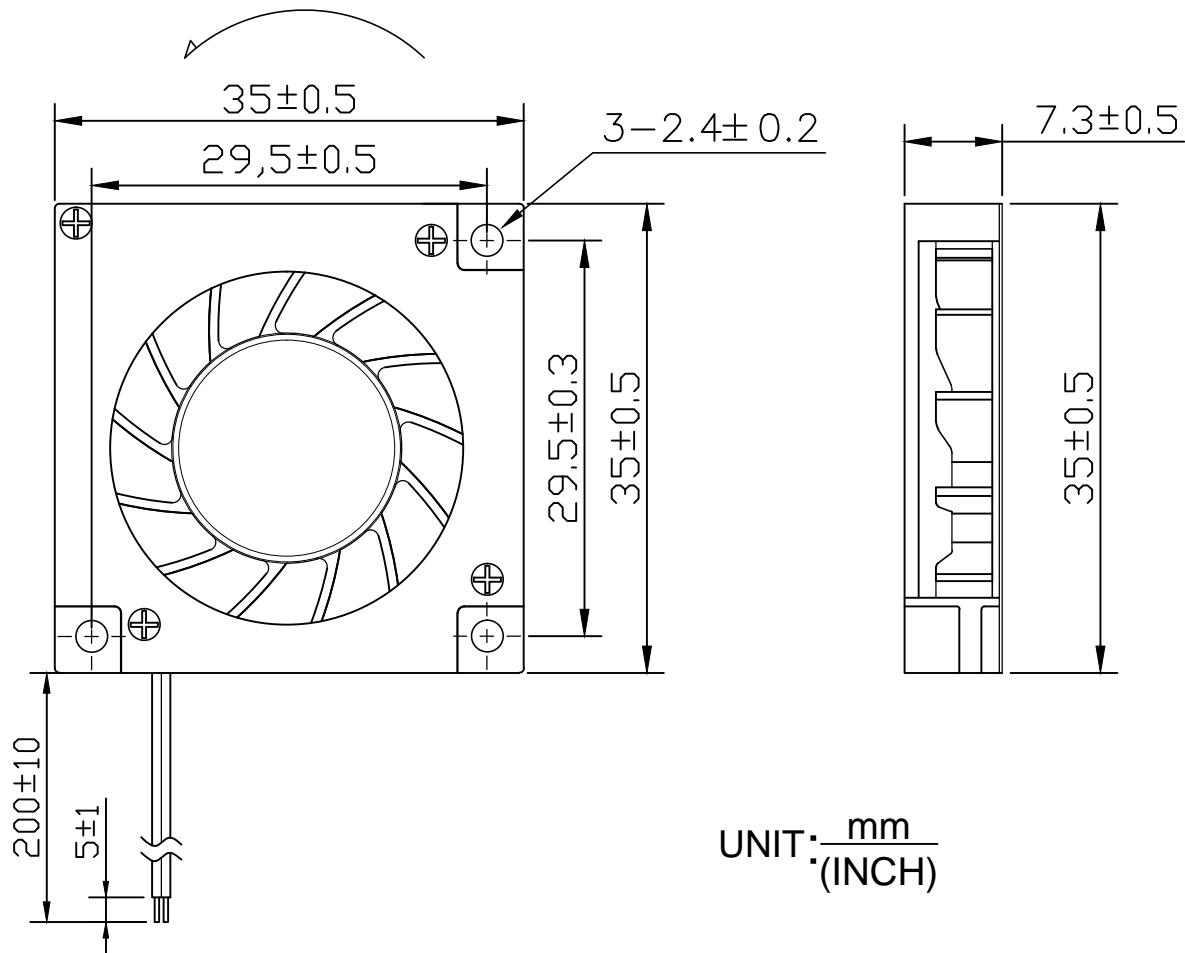

UNIT: $\frac{\text{mm}}{\text{(INCH)}}$

LEAD WIREUL 1061#26AWG OR EQUIVALENT
 1: BLACK WIRE---(-)
 2: RED WIRE---(+)



DATE
as:20211218

Mark 记号	REASON 变更原因	PROJECTION		单位 UNIT	深圳市腾凯特种机电有限公司					
				mm	SHEN ZHEN TENKAI GROUP LIMITED					
				比例 SCALE	型号	BA3507M12S		图号 Drawing NO.		
				1:1	Model NO.			BA3507M12S-A1801		
		公差 TOL	LINEAR .X .XX	ANGULAR	制图	朱蒸蒸	日期	2024.05.27	描述 Description	
			(0,50] ±0.10 ±0.05		X. ±0.5°	Drawing		日期	2024.05.27	DC BRUSHLESS BLOWER
			(50,100] ±0.20 ±0.10	X.X ±0.1°	检查	刘良军	日期	2024.05.27	材质 Material	页数 Page
			(100,+∞] ±0.30 ±0.15		批准		日期		表面 Finish	1/1
		It is prohibited to duplicate this document without explicit authorization or to hand it over to others for use.			Approved		日期		版次 Rev	A0

規格參數

SPECIFICATION

Model 型号:			
Item 项目	Unit 单位	Specification 參數	Condition 條件
Dimension 尺寸	Mm 毫米	35X35X7.3	LxWxThickness 长宽高
Bearing System 轴承类型	----	Hydraulic Bearing	----
Rated Voltage 额定电压	VDC	12	----
Operating Voltage Range 操作电压范围	VDC	7.5 ~ 13.5	At 25°C
Start-up Voltage 启动电压	VDC	≤7.5	At 25°C
Rated Current 额定电流	Amp 安培	0.09(Max)0.11	At Rated 在额定电压下
Lock Rotor Current 锁定电流	Amp 安培	0.11	Locked 锁死
Rated Power 额定功耗	Watt 瓦特	1.08	At Rated 在额定电压下
Rated Speed 额定转速	RPM 圈/分钟	7500±10%	AT Rated Voltage 30°C
Air Flow 风量	CFM	1.39	In Free Air 无风阻条件
Static Air Pressure 静压	mmH ₂ O	9.84	When Air Flow=0
Noise Level 噪音	dBA	32.3dBA	At Rated Speed 额定速
Polarity protection 反向保护	--	Reverse protection	Yes
Other Spec.	Tachometer Output 转速反馈		NO
	Soft-restart function 软启动		NO
	Lock Protection 锁定保护		NO
	Lock Rotor Alarm 锁定报警		NO
	PWM Control 速度控制		NO
	Thermal Control 过热保护		NO
	Over voltage protection 过压保护		NO
	Over current protection 过流保护		NO
	fixed constant speed Function 恒速功能		NO
Connection Lead Type 连接方式	Lead Wire 导线型号	200mm 1061#26AWG	See Page 2 见图纸
	Connector 端子	NO	Not Required
Life Expectancy 预期寿命	Hours 小时	30000hrs	At 25°C 在 25°C条件下
Net Weight 净重	g 克	7.3g	
备注 Note			

絕緣耐壓 Dielectric Strength	5Ma Max./導線与外框間測量，500VAC/min 5Ma Max./Measured between lead wire(+)and frame at 500VAC/min
極數 Number of Pole	4 極 4 Poles
EMC	Pass
運轉溫/濕度範圍 Operating temp. Range	溫度/temperature: -40°C~+80°C 濕度/Humidity: 35%~85%RH
絕緣阻抗 Insulation Resistance	10MΩ /裸線与外框間測量，500VDC/min 10MΩ/between unshackled wire and frame at 500VDC/min
耐濕性 Humidity	電器規格依據 MIL-STD 202F Method 103B 濕度: 95%RH, 溫度: 40±2°C According to MIL-STD 202F Method 103B Humidity: 95%RH,Temp.: 40±2°C
熱衝擊 Thermal Shock	電器規格依據 MIL-STD 202F Method 107D According to MIL-STD 202F Method 107D
絕緣階段 Insulation Shock	UL: A 種 UL: Class A
包裝耐振試驗 Packing Vibration Test	包裝后, XYZ 施 1.1KG 測試 30 分鐘無損壞 Load Vibration test for 30min,No serious damage

SHENZHEN TENKAI GROUP

MODEL NO.

BA3507M12S

MTBF REPORT

STARTED DATE: 2009.5.16

FINISHED DATE: 2009.10.20

TEST CONDITION TEST (1) VOLTAGE: 12VDC (2) TEMPERATURE: 75°C	ITEM	SPECIFICATION	TEST SAMPLES	20				
	OPERATION VOLTAGE	12VDC±10%	TEST HRS/EA	2,200				
	CURRENT DRAIN	MAX ≤ 0.09A	TOTAL TEST HRS	44,000				
	SPEED	7500RPM±10%	FAILURE Q'TY	0				
	ACOUSTICAL NOISE		CONFIDENCE LEVEL	90%				
			MTBF	30,574hours				
FAILURE DEFINITION (1) CURRENT: Over 10%/-30% of Original value (2) RPM: Over 30%/-15% of Original value (3) NOISE LEVEL: Over ±10% of origin	ITEM	CHECK POINT AT THE HOURS						
	TEST DURATION(HRS)	250	500	1k	1.5k	2k	2.2k	
	ACCUMULATED FAILURE Q'TY	0	0	0	0	0	0	
	SURVIVAL Q'TY	20	20	20	20	20	20	
	ACCUMULATED FAILURE RATIO	0%	0%	0%	0%	0%	0%	
	FAILNO.TEST TIME(HRS)SURVIVAL Q'TY ACCUMULATED FAIL RATIO DESCRIPTION							
TEST RESULT:	1. FORMULA OF FIGURING OUT ACCELERATION FACTOR: Tu : Required Temp (25°C) Ta : Experiment Temp.(75°C) $AF = 2^{\wedge} \left[\frac{Ta - Tu}{75 - 25} \right]$ $= 2^{\wedge} \left[\frac{75 - 25}{10} \right]$ $= 32$ $MTBF = [ACTUAL TEST TIME * SAMPLE Q'TY] * AF / TR / SAMPLE Q'TY$ $MTBF = [(2200 * 20) * 32] / 2.3026 / 20 = 30, 574 HOURS$					2. CONFIDENCE LEVEL: ACCORDING TO GEM TABLE 90% ZERO FAILURE TR=2.3026		
APPROVED BY: BOPING GONG	CHECKED BY: SHU LIN XIE			TESTED BY: JUN ZHANG				

风扇特性曲线风量风压测试报告

The Report of Fan Performance P-Q Curve Test

1. 产品特性依照 AMCA-210 标准在双箱里包括风量与风压的测试。

The performance including air flow and air pressure measured in Double Chamber is measured according to AMCA210-92 standard.

测试编号(No.): 2152

测试日期(Date) : 2017/11/25

2.测试数据:

序号 No.	项目 Item	规格 Specification	单位 Unit
1	测试电压 Test Voltage	12	VDC
2	转速 Speed	7500	RPM
3	大气压力 Barometric Pressure	761.5	mmHg
4	相对湿度 Relative Humidity	40	%
5	最大风量(零静压时)Max.Air Flow(At Zero Static Pressure)	1.4	CFM
6	最大风压 (零风量时) Max. Air Pressure(At Zero Air Flow)	9.8	mmH ₂ O

3.P-Q 数据及曲线 P-Q Data and Curve

序号	mmAq	CFM	A	Watt	RPM
1	9.84	0	0.09	1.08	
2	5.14	0.54	0.09	1.08	
3	1	1.18	0.09	1.08	
4	0	1.39	0.09	1.08	
5					
6					
7					
8					

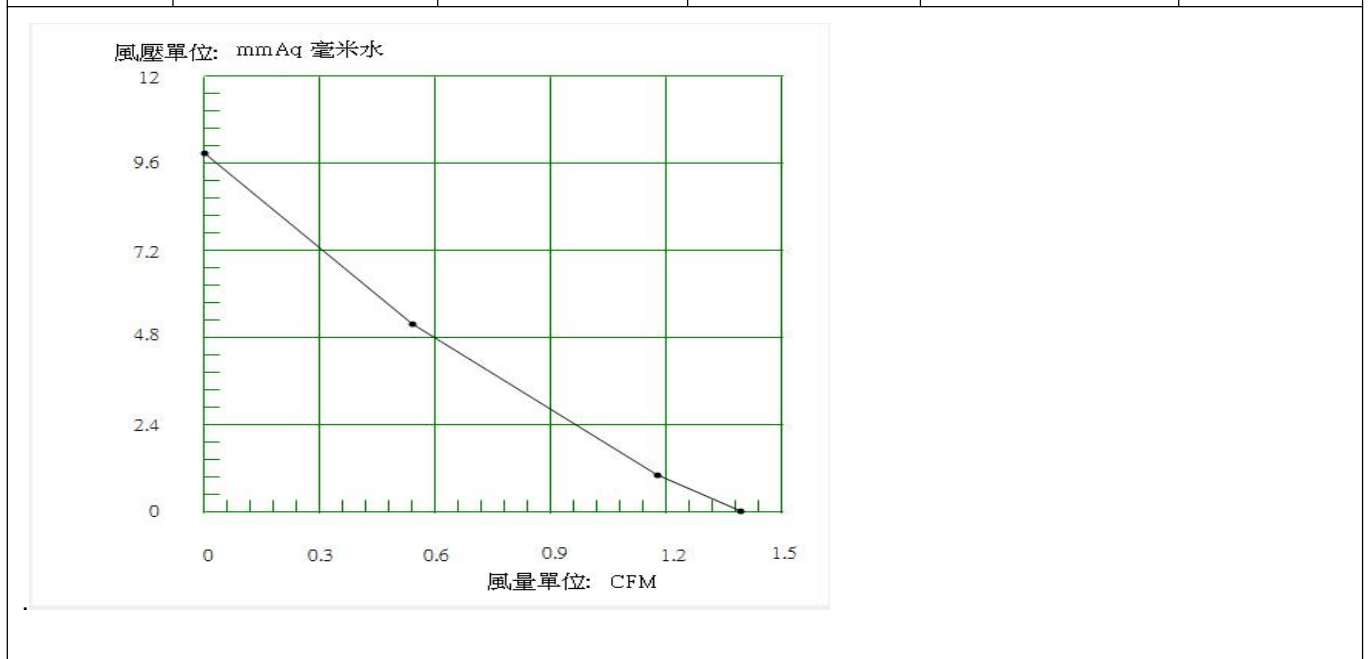

噪音测试报告

The Report of Acoustic Noise Test

报告编号 Report No.TN1511309

样品名称 Sample Name	Brushless Fan / Blower
测试条件 Test Condition	测试方法 Test Method
1.温度 Temperature: 31 °C 2.湿度 Humidity: 75 %RH	1.测试位置 Test Position : 180° 2.测试距离 Test Distance:1.0M From the fan intake 3.背景噪音 Background Noise: 19.1dB(A) 4.测试依照标准 ISO3745 执行 This test executes according to ISO3745 standard

测试设备 Test Equipment:
 声望 VA-Lab2 二通道噪声频谱分析仪 BSWA VA-Lab2 double channels noise Spectrum Analyzer

测试结果 Test Result: **Leq:32.3dB(A)**; 测试距离 Test distance: 1 meter

倍频段频谱图 Octave-Band(1m)

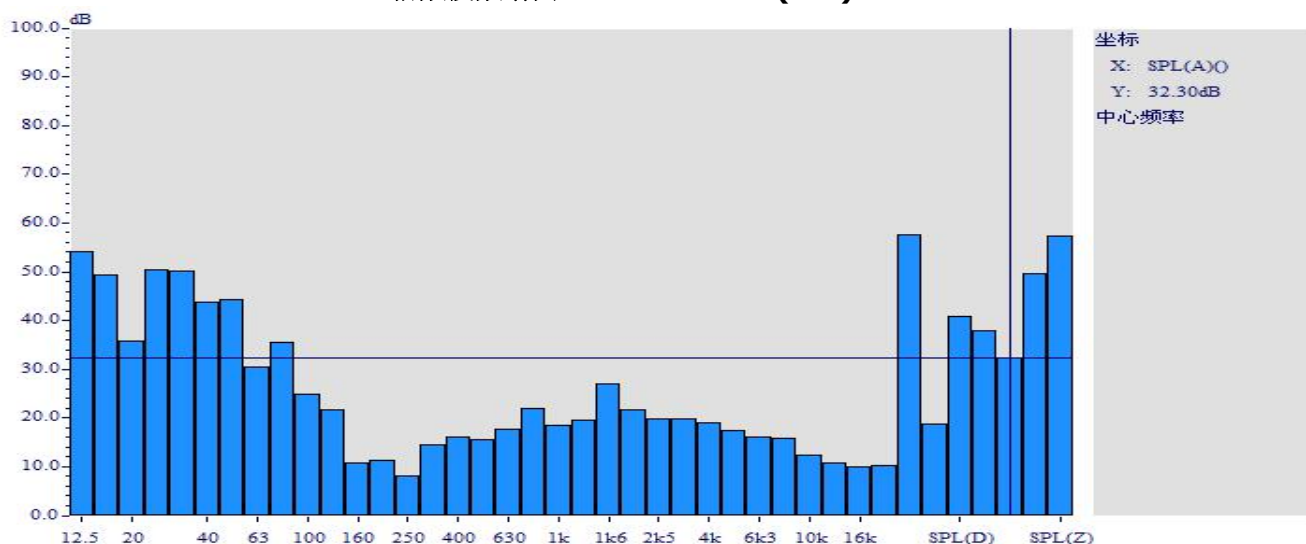

测试结果 Test Result: **Leq:16.1dB(A)**; 背景噪音 Background Noise

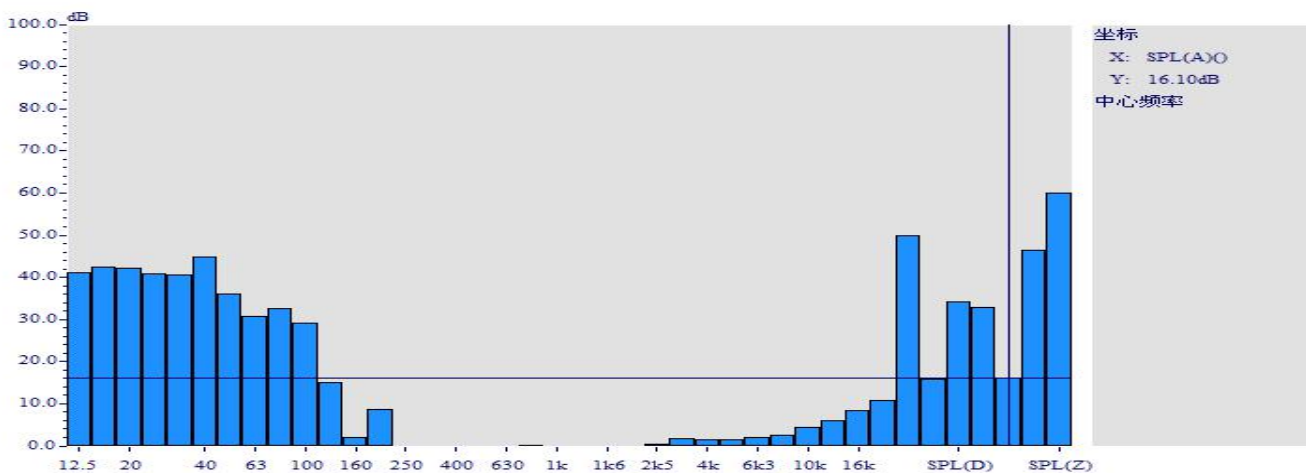

※本报告未经许可严禁擅自更改其中内容 Do not change the content of this report without written permission of authority;
 ※一般情况, 委托检验结果仅对所检验样品有效 Generally, commission test is responsible for the tested samples only;
 ※报告无主检、审核人签字无效 The test report is invalid without the signatures of Author and Reviewer.

实物图

The pictures

