

BA8060-B

BA8060H02B-B-Unintegrated



Features:

- 220 VAC rated input
- An external drive is required
- 0-5v or PWM input speed control
- High efficiency three-phase brushless DC motor
- Environmentally friendly materials

Advantages:

- High pressure 18.4kpa
- All aluminum material
- High temperature resistance
- Anti-corrosion
- waterproof
- High reliability
- Compact mini
- Low inertia

Applications:

- Vacuum system
- Air cushion machine
- Seafood transporter
- Pressure bed
- Lampblack exhaust system
- 3D Printer
- Medical equipment
- High voltage low noise applications

The TKFAN-BA8060H02B-B blower integrates high energy rare earth magnet technology to significantly improve the torque output efficiency; Frame and impeller are made of high-strength aluminum alloy, both lightweight and structural rigidity, more than 30% weight reduction than traditional steel, reduce the inertia load of equipment; Built-in high reliability ball bearing system, through precision machining and strengthening material technology, can withstand long-term high-speed operation of mechanical stress, extend the life cycle of equipment; With dust-proof and anti-corrosion treatment, to ensure stable operation in dust, wet and other complex environments.

With innovative technology and precision design at its core, TKFAN-BA8060H02B-B blower provides efficient and reliable airflow solutions for industrial and commercial applications. By integrating cutting-edge powertrains and optimized aerodynamics, the product achieves superior performance output in a compact volume, making it ideal for high-density spaces and demanding environments.

1. Technical Data

Electrical	Unit	Value
Dimension	[Mm]	79X77X60
Rated Voltage	[V _{ac}]	220(50HZ)
Voltage Range	[V _{ac}]	180 to 240
Rated Current	[A]	1.4
Rated Power	[W]	221
Rated Speed	[rpm/ms]	52 000
Static Pressure (When Air Flow= 0)	[Pa]	18365
Air Flow (In Free Air)	[l/min]	968

Environmental

Ambient temperature(operating)	[°C]	-40 to 60
Ambient temperature(storage)	[°C]	-40 to 60
Relative humidity(noncondensing)	[% RH]	10 to 85
Waterproof level		IP68
Maximumoxygen concentration	[%]	N/A

Motor

Type		Brushless motor
Winding insulation class		F, 155 °C
NTC type		N/A

Lifetime

L10 at 25 °C ambient temperature	[h]	10000
----------------------------------	-----	-------

Noise

Sound pressure level	[dB-A]	77.5
----------------------	--------	------

Mechanical

Blower weight	[g]	613
---------------	-----	-----

2. Mechanical Structure Diagram

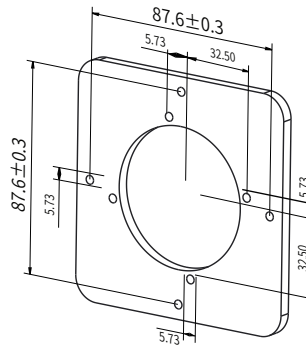
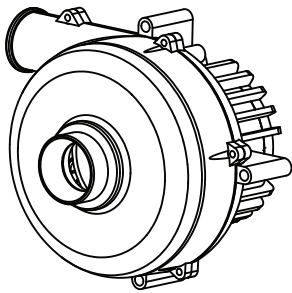
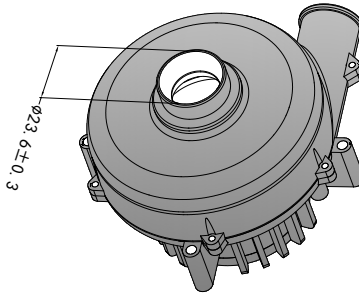
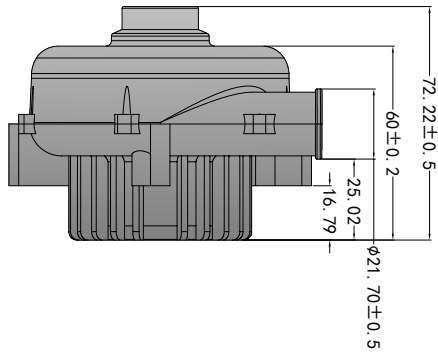

3. Drive Dimensions And Installation Hole Positions

3.1 Drive Dimensions

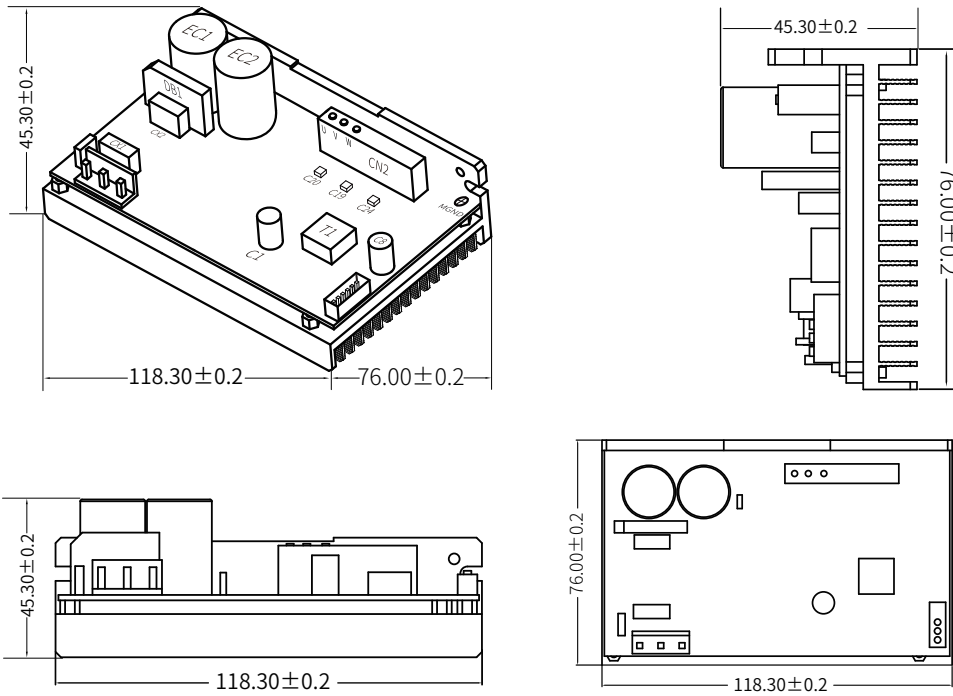

3.2 Installation Hole Positions

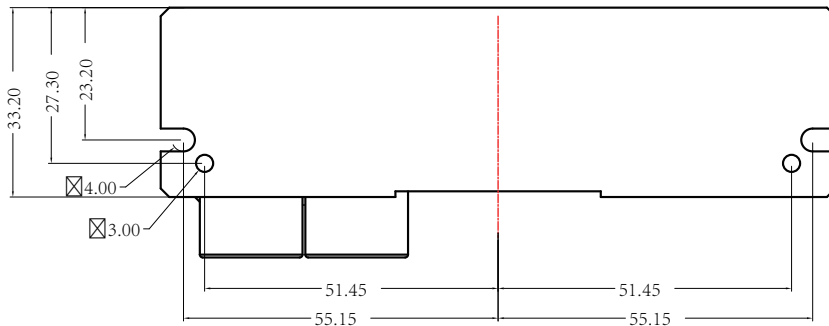

4. Electrical Connection Diagram

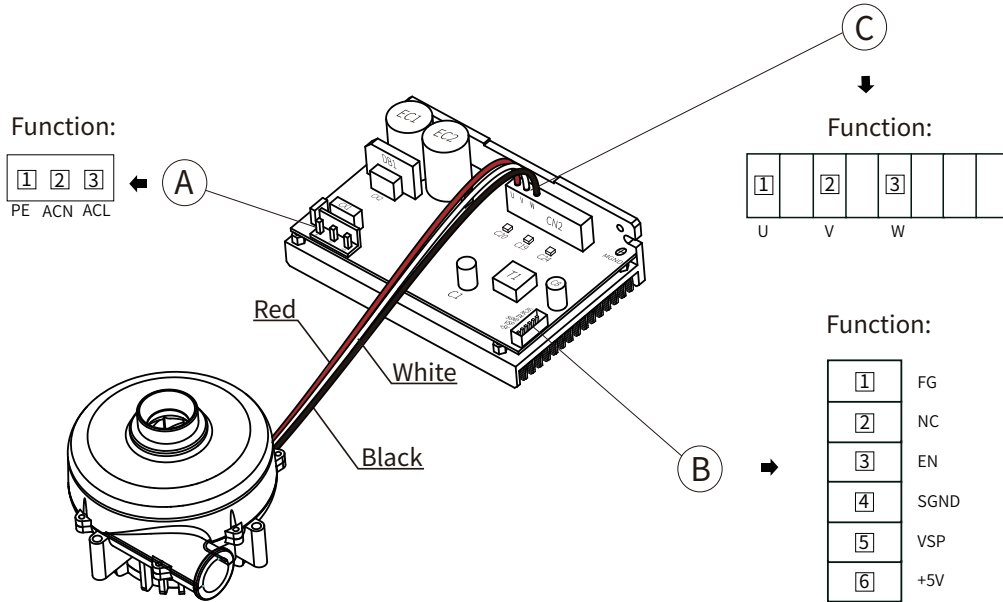

Wire model	Wire Number	Function
Ⓐ VH3.96	1	PE
	2	ACL
	3	ACN
Ⓑ 2.54	1	FG
	2	NC
	3	EN
	4	SGND
	5	VSP
	6	+5V
Ⓒ VH3.96	1	U
	2	V
	3	W

5. P-Q Data and Curve

5.1 PQ Curve

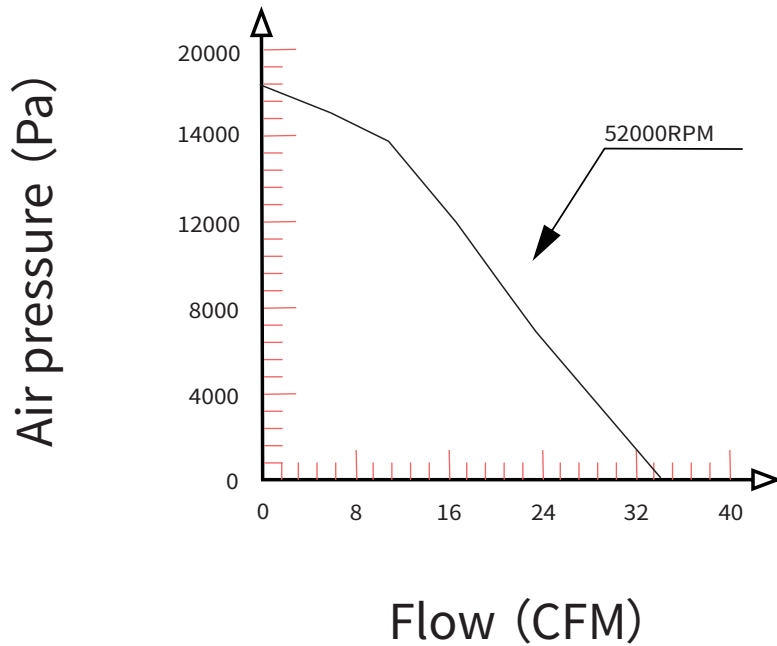

5.2 PQ Data

NO.	mmAq	CFM	A	Watt
1	1836.5	0		
2	1705.5	5.85		
3	1572.5	10.74		
4	1201.5	16.56		
5	907.75	20.46		
6	693.5	23.37		
7	546.25	25.61		
8	0	34.15		

6. PWM Curve

6.1 PWM Connecting Diagram

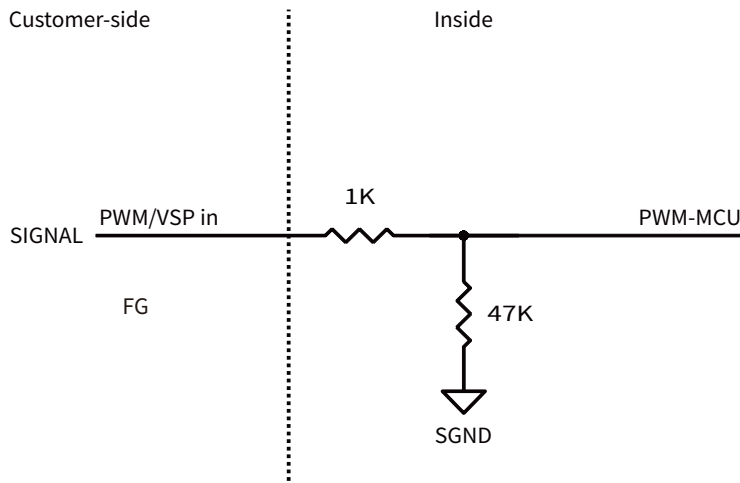

6.2 PWM data curve

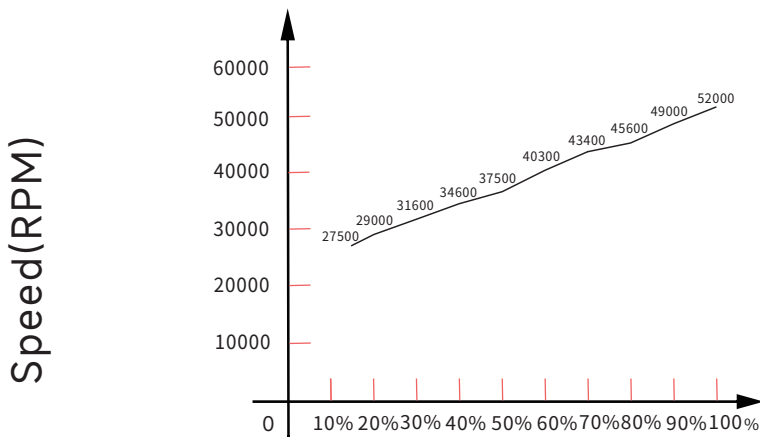

7. 0-5V Speed Control

7.1 5V Connetcting Diagram

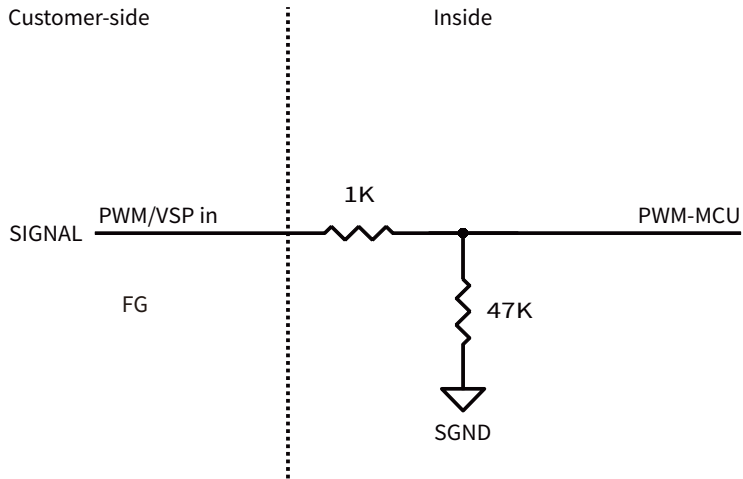

7.2 0-5V data curve

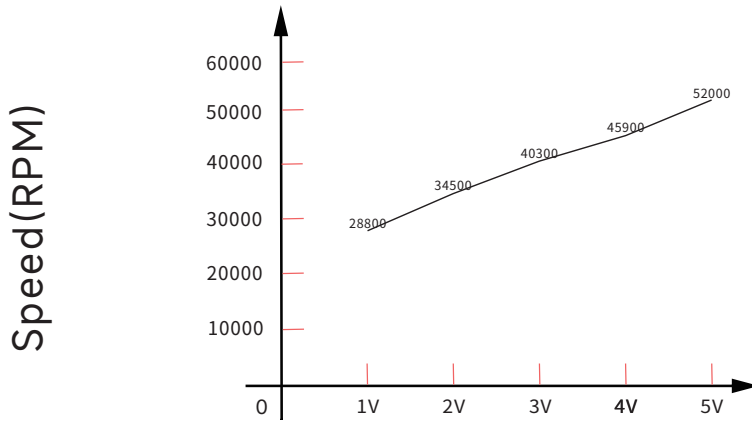

8. Control speed by Potentiometer

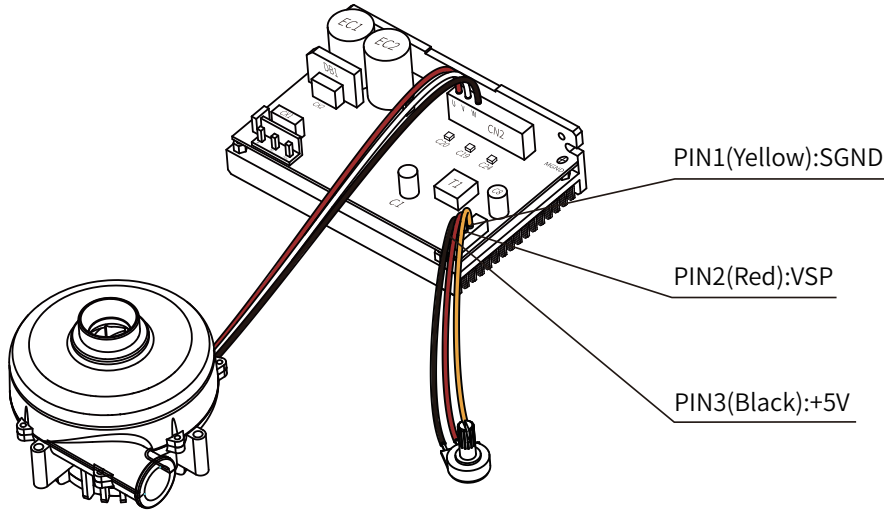

9. FG Speed Feedback Diagram

9.1 Signal output diagram

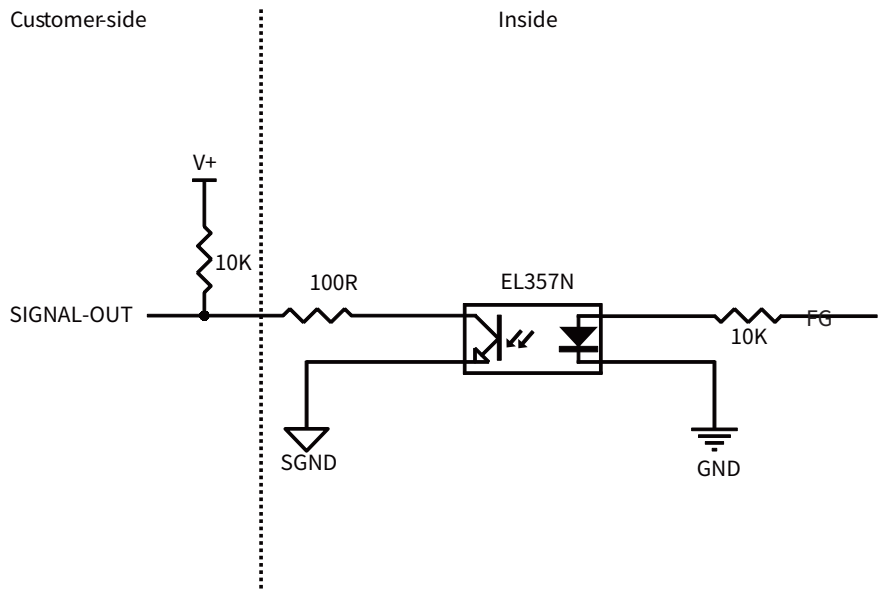

9.2 Rotational speed frequency

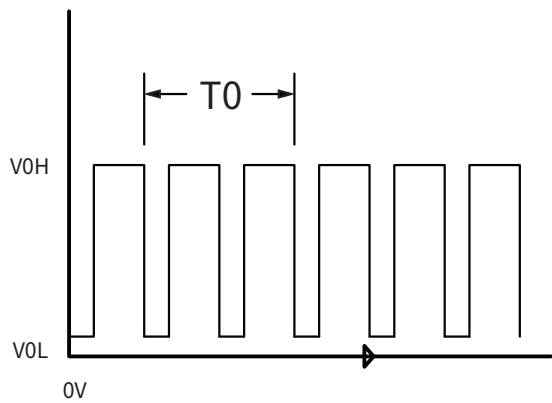

10. The EN signal controls the operation

10.1 Blower control is available when EN in is high level or disconnected

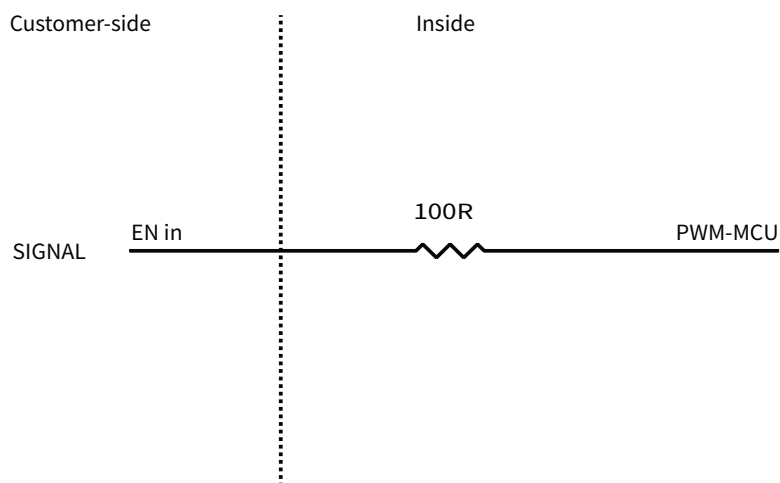

10.2 Blower will be stop working when EN signal in is low level

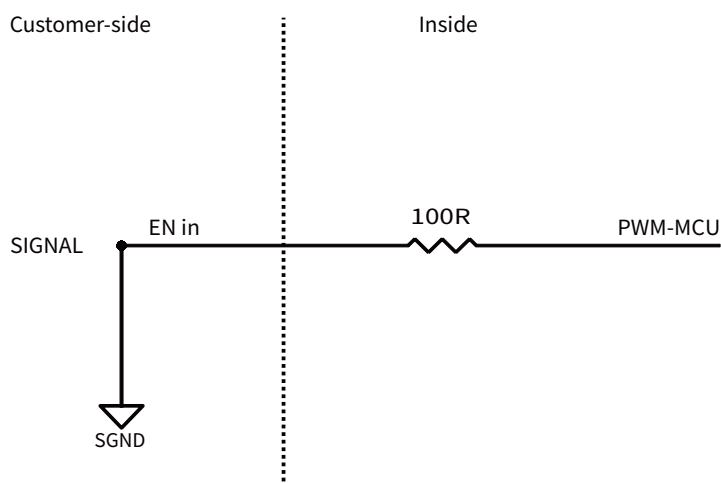

11. Temperature Test Report

12. Related Products

Model	Dimension	Voltage	RPM	Air Flow	Air Pressure	Watt

TAKE A CLOSER LOOK

TK FAN solutions for a wide variety of applications, including medical, automation, packaging, industrial, aerospace and defense are only a click away. Visit our worldwide web site for more information.

For product information, vis www.tkfan.com

For more information or the office nearest you, contact us online, sales@tenkai-group.com

However, to ensure that you can smoothly find the relevant person in charge and receive timely reception, it is recommended that you make an appointment in advance by phone or email.